

1. General Description

The 74HC245; 74HCT245 are 8-bit transceivers with 3-state outputs. The device features an output enable (\overline{OE}) and send/receive (DIR) for direction control. A HIGH on \overline{OE} causes the outputs to assume a high-impedance OFF-state. Inputs include clamp diodes. This enables the use of current limiting resistors to interface inputs to voltages in excess of V_{CC} .

2. Features and Benefits

- Wide supply voltage range from 2.0 V to 6.0 V
- High noise immunity
- CMOS low power dissipation
- Latch-up performance exceeds 250 mA
- Octal bidirectional bus interface
- Non-inverting 3-state outputs
- Complies with JEDEC standards:
 - JESD8C (2.7 V to 3.6 V)
 - JESD7A (2.0 V to 6.0 V)
- Input levels:
 - For 74HC245: CMOS level
 - For 74HCT245: TTL level
- ESD protection:
 - HBM ANSI/ESDA/JEDEC JS-001 Class 3A exceeds 6000 V
 - CDM ANSI/ESDA/JEDEC JS-002 Class C3 exceeds 2000 V
- Multiple package options

3. Ordering Information

Table 1. Ordering information

Type number	Package		
	Name	Description	Quantity
74HC245D	SOP-20L	plastic small outline package; 20 leads; body width 7.5 mm	2000
74HC245PW	TSSOP-20L	plastic thin shrink small outline package; 20 leads; body width 4.4 mm	2000

4. Function Diagram

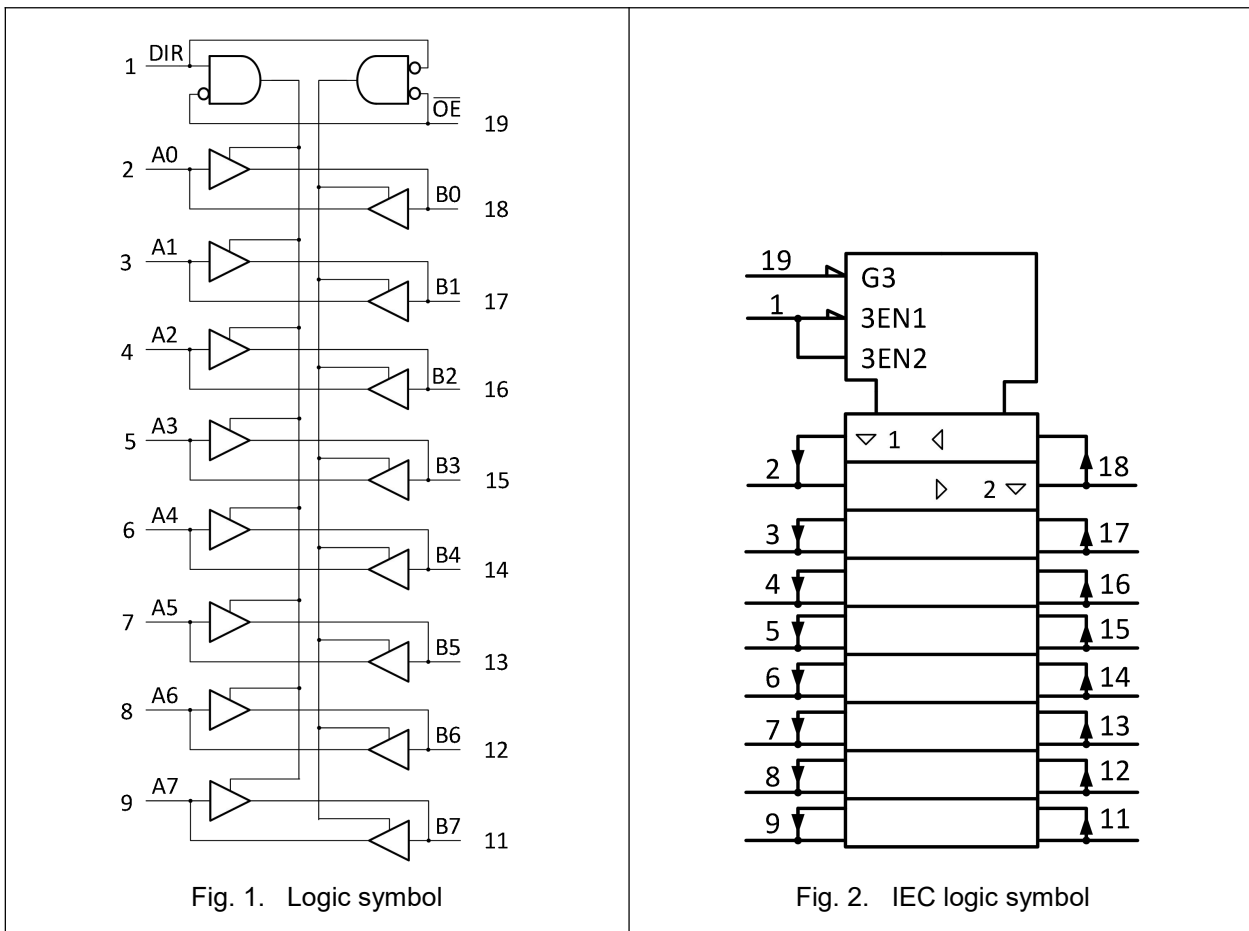

5. Pinning Information

5.1. Pinning

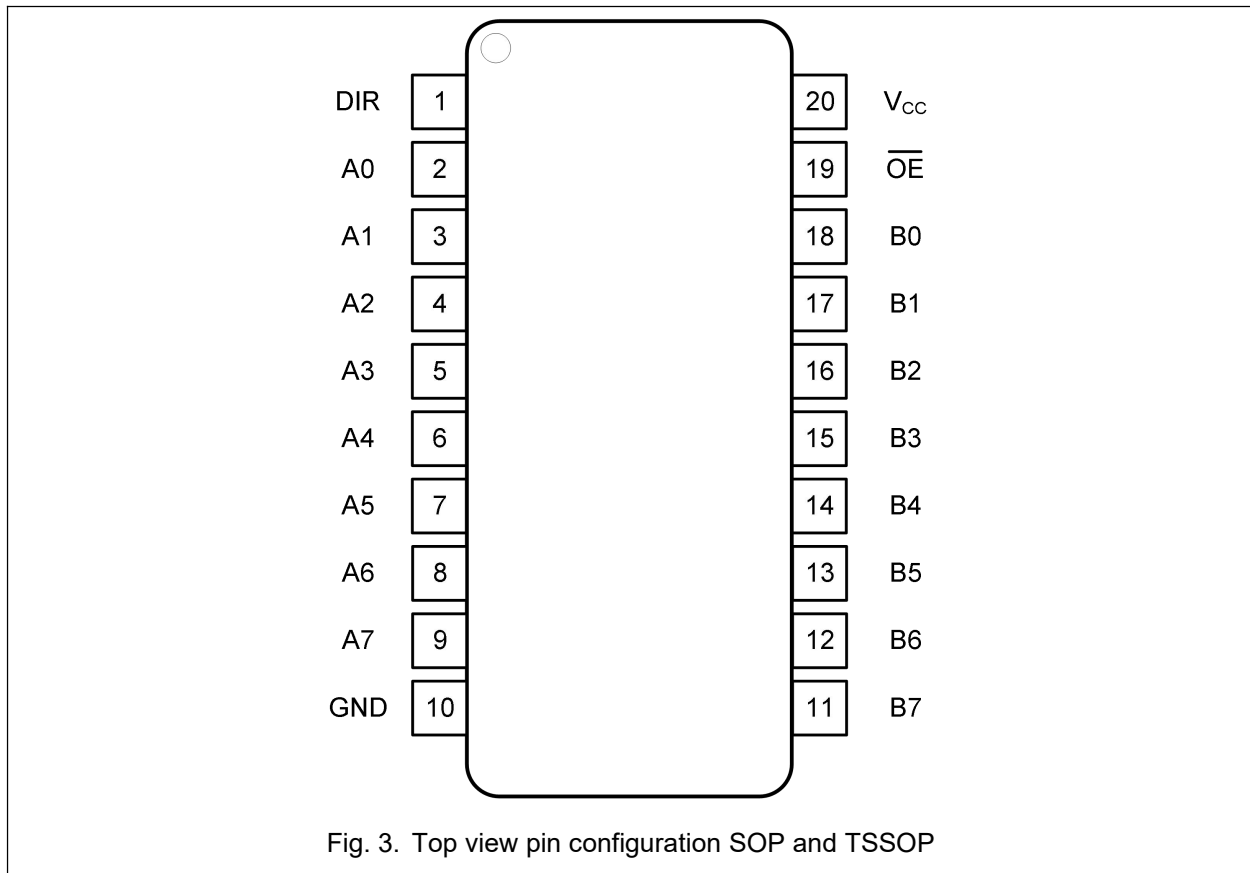

5.2. Pin description

Table 2. Pin description

Symbol	Pin	Description
DIR	1	Direction control
A0, A1, A2, A3, A4, A5, A6, A7	2, 3, 4, 5, 6, 7, 8, 9	Data input/output
GND	10	Ground (0 V)
B7, B6, B5, B4, B3, B2, B1, B0	11, 12, 13, 14, 15, 16, 17, 18	Data input/output
\overline{OE}	19	Output enable input (active LOW)
V _{cc}	20	Supply voltage

6. Functional Description

Table 3. Function table

H = HIGH voltage level; L = LOW voltage level; X = don't care; Z = high-impedance OFF-state.

Input		Input/output	
\overline{OE}	DIR	An	Bn
L	L	A = B	input
L	H	input	B = A
H	X	Z	Z

7. Absolute Maximum Ratings

Stresses exceeding the absolute maximum ratings may damage the device. The device may not function or be operable above the recommended operating conditions and stressing the parts to these levels is not recommended. In addition, extended exposure to stresses above the recommended operating conditions may affect device reliability. The absolute maximum ratings are stress ratings only.

Table 4. Absolute Maximum Ratings

In accordance with the Absolute Maximum Rating System (IEC 60134). Voltages are referenced to GND.

Symbol	Parameter	Conditions	Min	Max	Unit
V_{CC}	supply voltage		-0.5	7.0	V
I_{IK}	input clamping current	$V_I < -0.5\text{ V}$ or $V_I > V_{CC} + 0.5\text{ V}$ [1]		± 20	mA
I_{OK}	output clamping current	$V_O < -0.5\text{ V}$ or $V_O > V_{CC} + 0.5\text{ V}$ [1]		± 20	mA
I_O	output current	$V_O = -0.5\text{ V}$ to $(V_{CC} + 0.5\text{ V})$		± 25	mA
I_{CC}	supply current			50	mA
I_{GND}	ground current		-50		mA
P_{tot}	total power dissipation			500	mW
T_{stg}	storage temperature		-65	150	°C

[1] The input and output voltage ratings may be exceeded if the input and output current ratings are observed.

8. Recommended Operating Conditions

The Recommended Operating Conditions table defines the conditions for actual device operation. Recommended operating conditions are specified to ensure optimal performance to the datasheet specifications. MDD does not recommend exceeding them or designing to Absolute Maximum Ratings.

Table 5. Recommended Operating Conditions

Symbol	Parameter	Conditions	74HC245			74HCT245			Unit
			Min	Typ	Max	Min	Typ	Max	
V _{CC}	supply voltage		2.0	5.0	6.0	2.7	5.0	5.5	V
V _I	input voltage		0		V _{CC}	0		V _{CC}	V
V _O	output voltage		0		V _{CC}	0		V _{CC}	V
T _{amb}	ambient temperature		-40		125	-40		125	°C
Δt/ΔV	input transition rise and fall rate	V _{CC} = 2.0 V			625				ns/V
		V _{CC} = 4.5 V		1.67	139		1.67	139	ns/V
		V _{CC} = 6.0 V			83				ns/V

9. Static Characteristics

Table 6. Static characteristics

At recommended operating conditions. Voltages are referenced to GND (ground = 0 V). Typical values measured at $T_{amb} = 25^{\circ}\text{C}$ (unless otherwise noted).

Symbol	Parameter	Conditions	-40 °C to +85 °C			-40 °C to +125 °C		Unit
			Min	Typ	Max	Min	Max	
74HC245								
V_{IH}	HIGH-level input voltage	$V_{CC} = 2.0\text{ V}$	1.5			1.5		V
		$V_{CC} = 4.5\text{ V}$	3.15			3.15		V
		$V_{CC} = 6.0\text{ V}$	4.2			4.2		V
V_{IL}	LOW-level input voltage	$V_{CC} = 2.0\text{ V}$			0.5		0.5	V
		$V_{CC} = 4.5\text{ V}$			1.35		1.35	V
		$V_{CC} = 6.0\text{ V}$			1.8		1.8	V
V_{OH}	HIGH-level output voltage	$V_I = V_{IH}\text{ or }V_{IL}$						
		$I_O = -20\ \mu\text{A}; V_{CC} = 2.0\text{ V}$	1.9			1.9		V
		$I_O = -20\ \mu\text{A}; V_{CC} = 4.5\text{ V}$	4.4			4.4		V
		$I_O = -20\ \mu\text{A}; V_{CC} = 6.0\text{ V}$	5.9			5.9		V
		$I_O = -6.0\text{ mA}; V_{CC} = 4.5\text{ V}$	3.84			3.7		V
		$I_O = -7.8\text{ mA}; V_{CC} = 6.0\text{ V}$	5.34			5.2		V
V_{OL}	LOW-level output voltage	$V_I = V_{IH}\text{ or }V_{IL}$						
		$I_O = 20\ \mu\text{A}; V_{CC} = 2.0\text{ V}$			0.1		0.1	V
		$I_O = 20\ \mu\text{A}; V_{CC} = 4.5\text{ V}$			0.1		0.1	V
		$I_O = 20\ \mu\text{A}; V_{CC} = 6.0\text{ V}$			0.1		0.1	V
		$I_O = 6.0\text{ mA}; V_{CC} = 4.5\text{ V}$			0.33		0.4	V
		$I_O = 7.8\text{ mA}; V_{CC} = 6.0\text{ V}$			0.33		0.4	V
I_I	input leakage current	$V_I = V_{CC}\text{ or GND}; V_{CC} = 6.0\text{ V}$			± 1		± 1	μA
I_{OZ}	OFF-state output current	$V_I = V_{IH}\text{ or }V_{IL}; V_{CC} = 6.0\text{ V}; V_O = V_{CC}\text{ or GND}$			± 5		± 10	μA
I_{CC}	supply current	$V_I = V_{CC}\text{ or GND}; I_O = 0\text{ A}; V_{CC} = 6.0\text{ V}$			20		40	μA
C_I	input capacitance			4.0				pF
$C_{I/O}$	Input/output capacitance			7.7				pF

74HC245; 74HCT245
Octal buffer/line driver; 3-state

Symbol	Parameter	Conditions	-40 °C to +85 °C			-40 °C to +125 °C		Unit
			Min	Typ	Max	Min	Max	
74HCT245								
V _{IH}	HIGH-level input voltage	V _{CC} = 3 V	2.0			2.0		V
		V _{CC} = 4.5 V	2.0			2.0		V
		V _{CC} = 5.5 V	2.1			2.1		V
V _{IL}	LOW-level input voltage	V _{CC} = 3 V			0.8		0.8	V
		V _{CC} = 4.5 V			0.8		0.8	V
		V _{CC} = 5.5 V			0.8		0.8	V
V _{OH}	HIGH-level output voltage	V _I = V _{IH} or V _{IL} ;						
		I _O = -20 μA; V _{CC} = 3 V	2.9			2.9		V
		I _O = -20 μA; V _{CC} = 4.5 V	4.4			4.4		V
		I _O = -6.0 mA; V _{CC} = 4.5 V	3.84			3.7		V
V _{OL}	LOW-level output voltage	V _I = V _{IH} or V _{IL} ;						
		I _O = 20 μA; V _{CC} = 3 V			0.1		0.1	V
		I _O = 20 μA; V _{CC} = 4.5 V			0.1		0.1	V
		I _O = 6.0 mA; V _{CC} = 4.5 V			0.33		0.4	V
I _I	input leakage current	V _I = V _{CC} or GND ; V _{CC} = 5.5 V			±1		±1	μA
I _{OZ}	OFF-state output current	V _I = V _{IH} or V _{IL} ; V _{CC} = 5.5 V ; V _O = V _{CC} or GND			±5		±10	μA
I _{CC}	supply current	V _I = V _{CC} or GND; I _O = 0 A; V _{CC} = 5.5 V			20		40	μA
ΔI _{CC}	additional supply current	per pin ; V _I = V _{CC} - 2.1 V; I _O = 0 A; other inputs at V _{CC} or GND; V _{CC} = 4.5 V to 5.5 V			400		490	μA
C _I	input capacitance			4.0				pF
C _{I/O}	Input/output capacitance			7.7				pF

10. Dynamic Characteristics

Table 7. Dynamic characteristics

Voltages are referenced to GND (ground = 0 V); for test circuit see Fig. 6. Typical values measured at $T_{amb} = 25^{\circ}\text{C}$ (unless otherwise noted).

Symbol	Parameter	Conditions	-40 °C to +85 °C			-40 °C to +125 °C		Unit
			Min	Typ	Max	Min	Max	
74HC245								
t_{pd}	propagation delay	An to Bn or Bn to An; see Fig. 4 [1]						
		$V_{CC} = 2.0\text{ V}$			35		40	ns
		$V_{CC} = 4.5\text{ V}$			20		25	ns
		$V_{CC} = 6.0\text{ V}$			15		20	ns
t_{en}	enable time	\overline{OE} to An or Bn; see Fig. 5 [2]						
		$V_{CC} = 2.0\text{ V}$			35		40	ns
		$V_{CC} = 4.5\text{ V}$			20		25	ns
		$V_{CC} = 6.0\text{ V}$			15		20	ns
t_{dis}	disable time	\overline{OE} to An or Bn; see Fig. 5 [3]						
		$V_{CC} = 2.0\text{ V}$			35		40	ns
		$V_{CC} = 4.5\text{ V}$			20		25	ns
		$V_{CC} = 6.0\text{ V}$			15		20	ns
t_t	transition time	see Fig. 4 [4]						
		$V_{CC} = 2.0\text{ V}$			9		11	ns
		$V_{CC} = 4.5\text{ V}$			6		8	ns
		$V_{CC} = 6.0\text{ V}$			4		5	ns
C_{PD}	power dissipation capacitance	per buffer; $V_i = \text{GND to } V_{CC}$ [5]		18				pF

74HC245; 74HCT245

Octal buffer/line driver; 3-state

Symbol	Parameter	Conditions	-40 °C to +85 °C			-40 °C to +125 °C		Unit
			Min	Typ	Max	Min	Max	
74HCT245								
t_{pd}	propagation delay	An to Bn or Bn to An; $V_{CC} = 4.5V$; see Fig. 4 [1]			20		25	ns
t_{en}	enable time	\overline{OE} to An or Bn; $V_{CC} = 4.5V$; see Fig. 5 [2]			20		25	ns
t_{dis}	disable time	\overline{OE} to An or Bn; $V_{CC} = 4.5V$ see Fig. 5 [3]			20		25	ns
t_t	transition time	$V_{CC}=4.5V$; see Fig. 4; [4]			6		8	ns
C_{PD}	power dissipation capacitance	per buffer; $V_I = GND$ to $V_{CC} - 1.5 V$ [5]		18				pF

[1] t_{pd} is the same as t_{PHL} and t_{PLH} .

[2] t_{en} is the same as t_{PZH} and t_{PZL} .

[3] t_{dis} is the same as t_{PLZ} and t_{PHZ} .

[4] t_t is the same as t_{THL} and t_{TLH} .

[5] C_{PD} is used to determine the dynamic power dissipation (P_D in μW).

$P_D = C_{PD} \times V_{CC}^2 \times f_i \times N + \Sigma(C_L \times V_{CC}^2 \times f_o)$ where:

f_i = input frequency in MHz;

f_o = output frequency in MHz;

C_L = output load capacitance in pF;

V_{CC} = supply voltage in V;

N = number of inputs switching;

$\Sigma(C_L \times V_{CC}^2 \times f_o)$ = sum of outputs.

10.1. Waveforms and test circuit

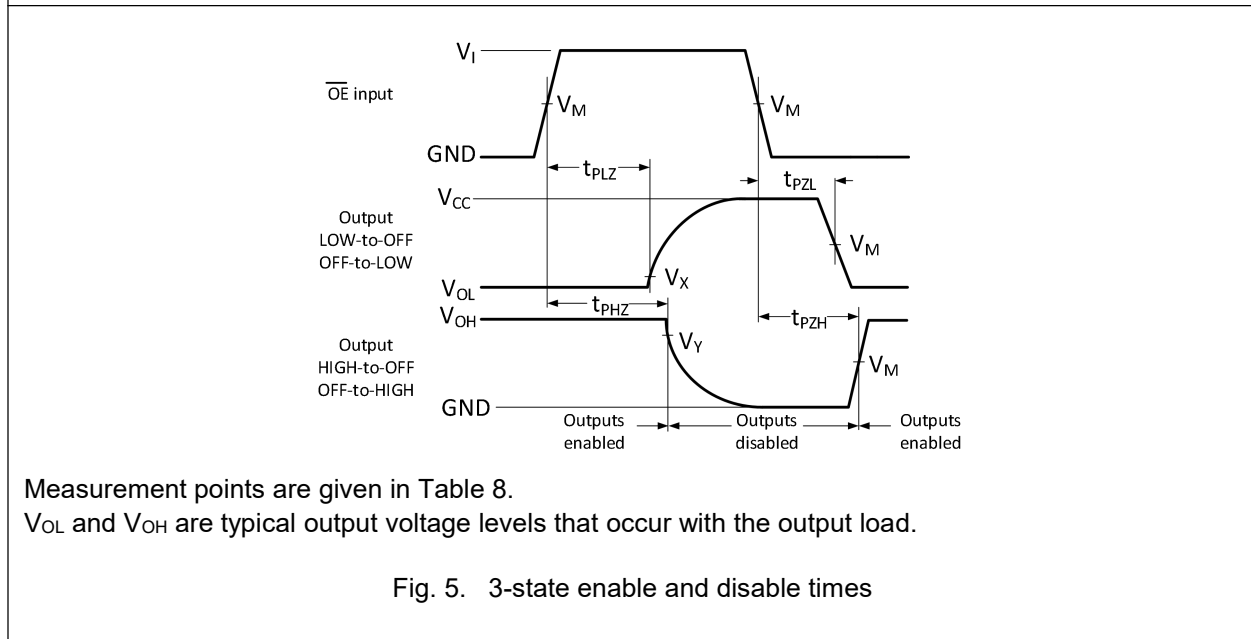
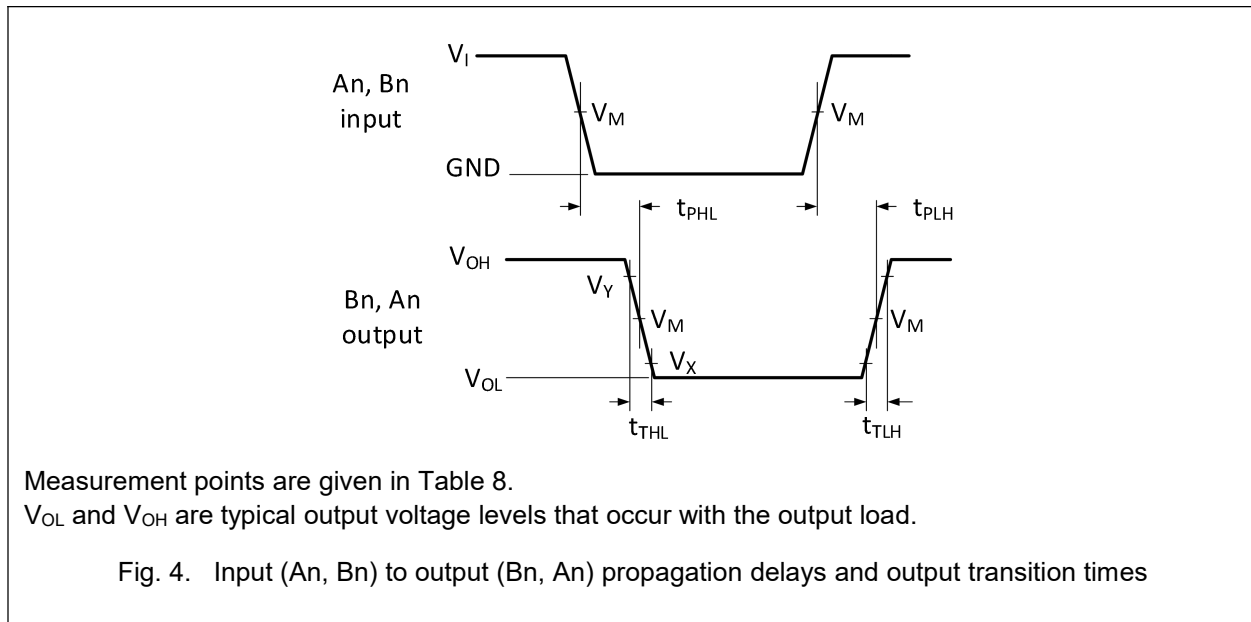

Table 8. Measurement points

Type	Input	Output		
	V_M	V_M	V_X	V_Y
74HC245	$0.5V_{CC}$	$0.5V_{CC}$	$0.1V_{CC}$	$0.9V_{CC}$
74HCT245	1.3 V	1.3 V	$0.1V_{CC}$	$0.9V_{CC}$

74HC245; 74HCT245

Octal buffer/line driver; 3-state

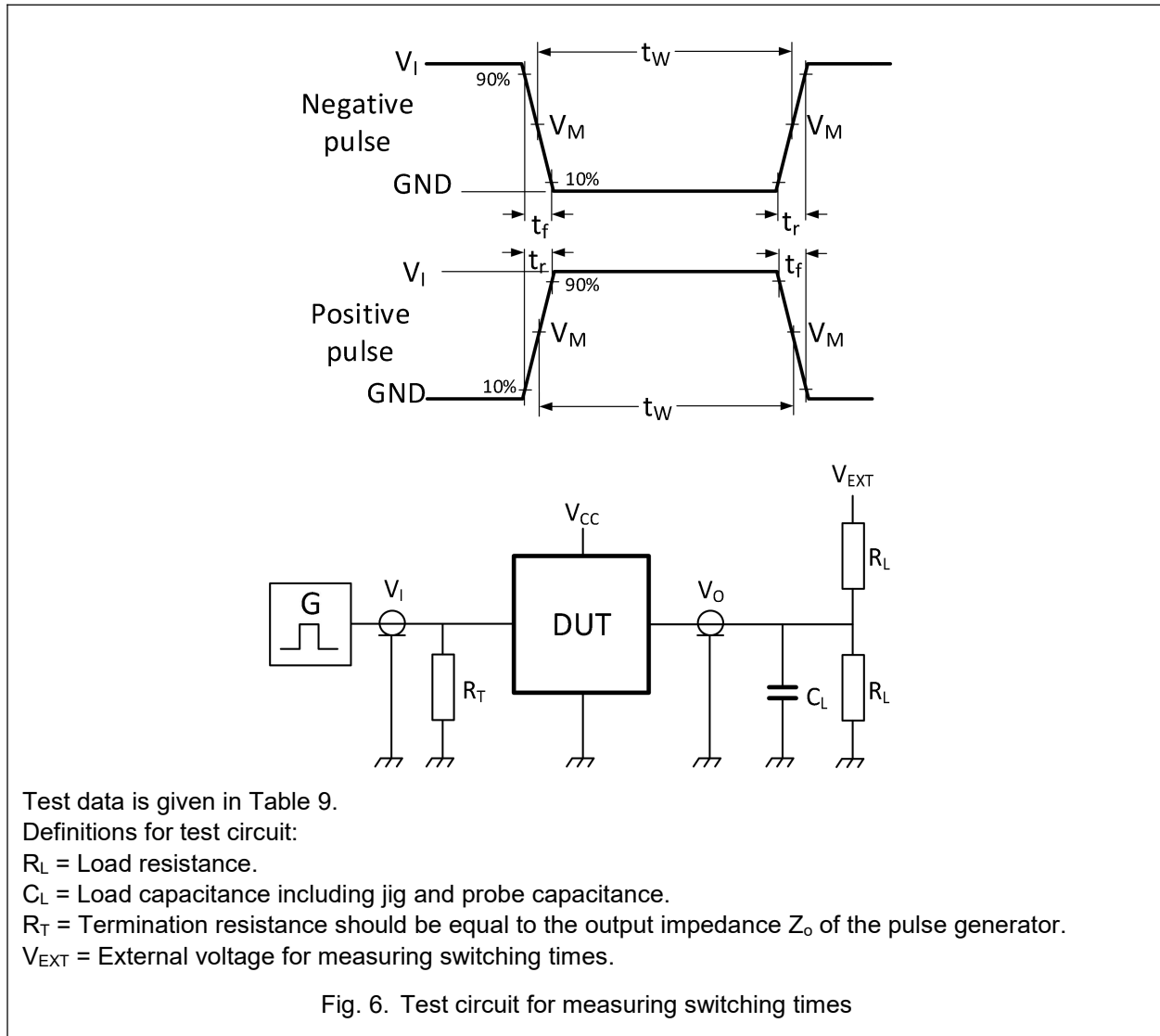
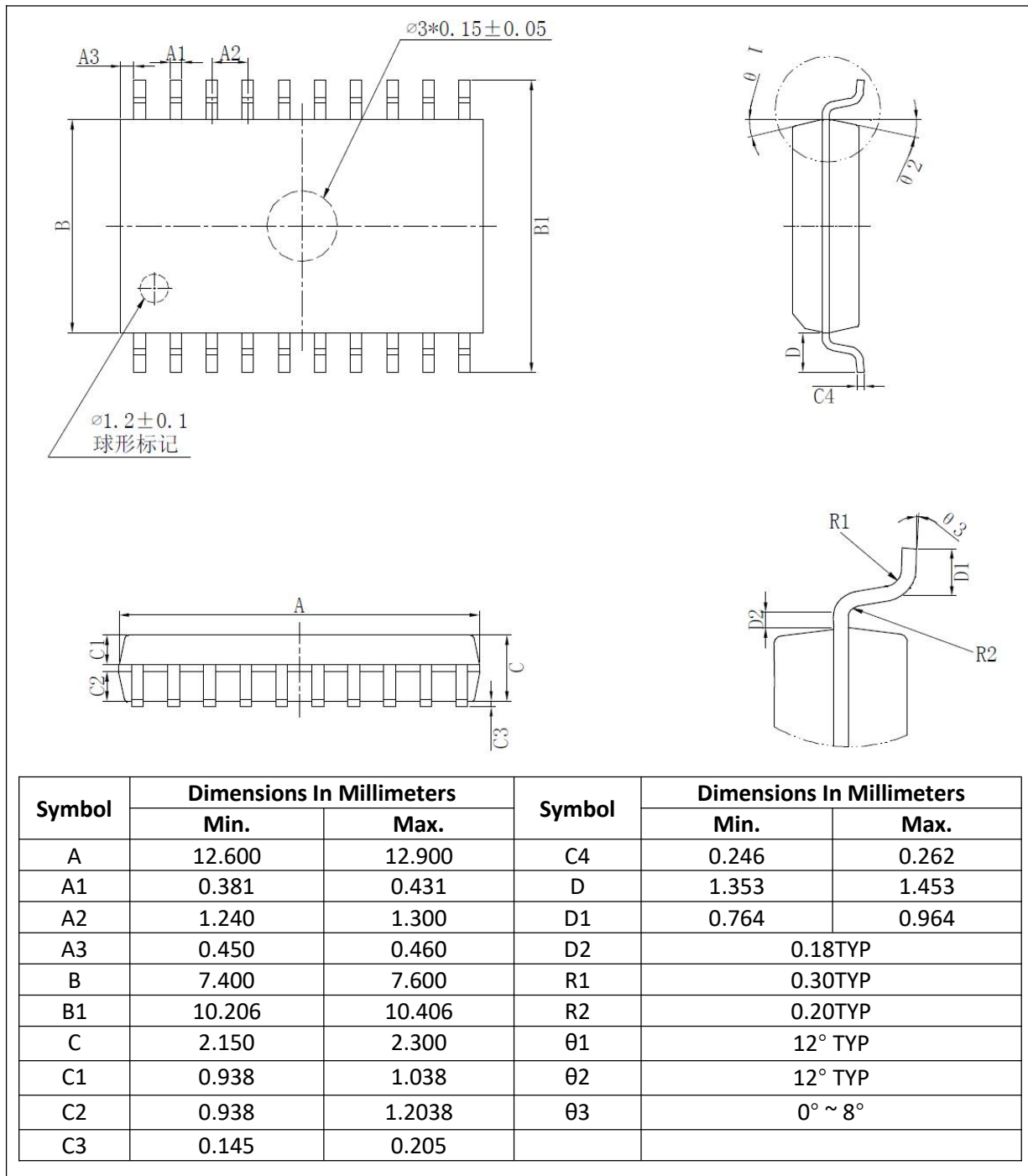

Table 9. Test data

Type	Input		Load		V_{EXT}		
	V_I	$t_r = t_f$	C_L	R_L	t_{PLH}, t_{PHL}	t_{PZH}, t_{PHZ}	t_{PZL}, t_{PLZ}
74HC245	V_{CC}	≤ 2.5 ns	50 pF	500 Ω	open	GND	$2V_{CC}$
74HCT245	3 V	≤ 2.5 ns	50 pF	500 Ω	open	GND	$2V_{CC}$

11. Package Outline

SOP-20L



74HC245; 74HCT245

Octal buffer/line driver; 3-state

TSSOP-20L

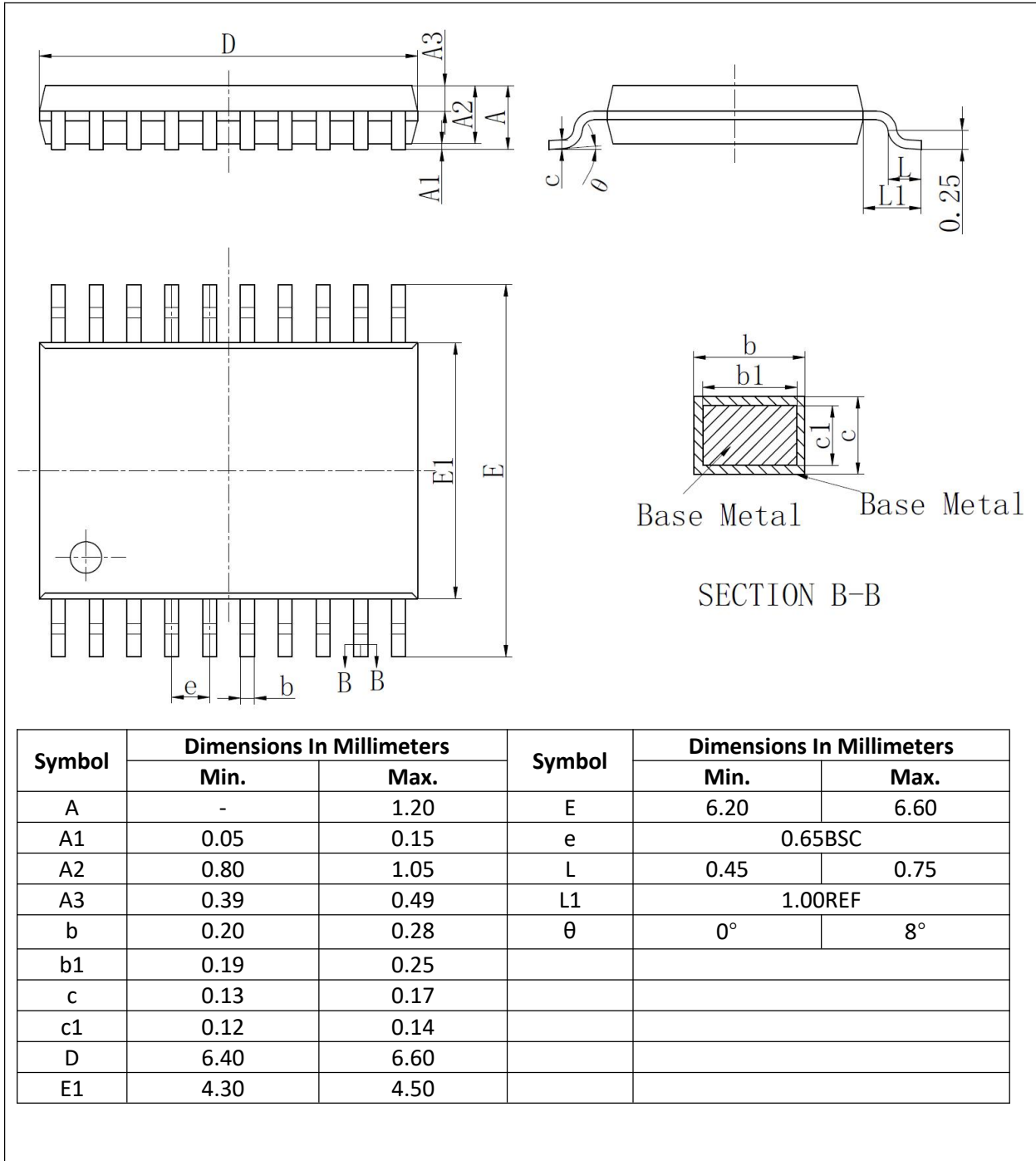

12. Abbreviations

Table 10. Abbreviations

Acronym	Description
CMOS	Complementary Metal-Oxide Semiconductor
DUT	Device Under Test
ESD	ElectroStatic Discharge
HBM	Human Body Model
CDM	Charged Device Model

13. Revision History

Table 11. Revision history

Document ID	Release Date	Data sheet status	Change notice	Supersedes
74HC_HCT245 Rev. 1.0	Apr 18, 2025	Product datasheet		